

GB **Operating Instructions for the  
Indoor and Outdoor Device**

**PRO KLIMA**  
Klimageräte

**Split-system Air Conditioner**



**Important note:**

**This high-quality product will only offer optimum service if installed correctly and in the right place, and is put into operation for the first time by a suitably competent person. Avoid malfunctions by seeking competent advice from an expert with regards to the location, installation and starting up of the system.**

**We shall accept no liability for malfunctions or inadequate cooling performance resulting from the improper handling of the product.**

**The socket-outlet required to supply power must be connected and commissioned by a specialist contractor.**

**If the system is to be moved to another location or disposed of, only a suitably qualified electrician's/cooling system firm is permitted to undertake any work of disassembly or disposal.**

**7**



**Art.-Nr.: 23.658.20**

**I.-Nr.: 01017**

**Split 900 FLAT EQ C+H**

**Art.-Nr.: 23.658.21**

**I.-Nr.: 01017**

**Split 1200 FLAT EQ C+H**

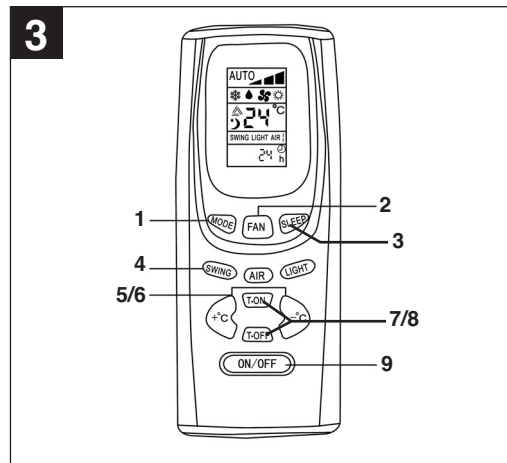
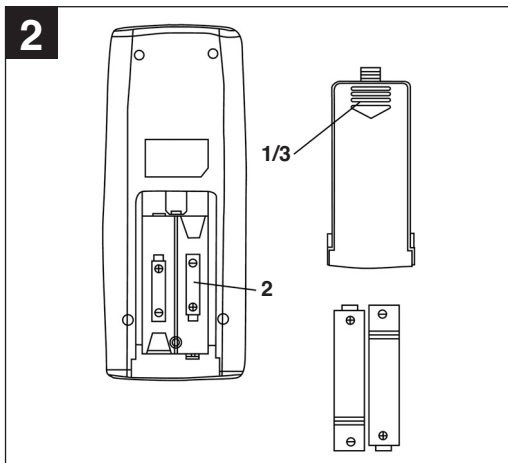
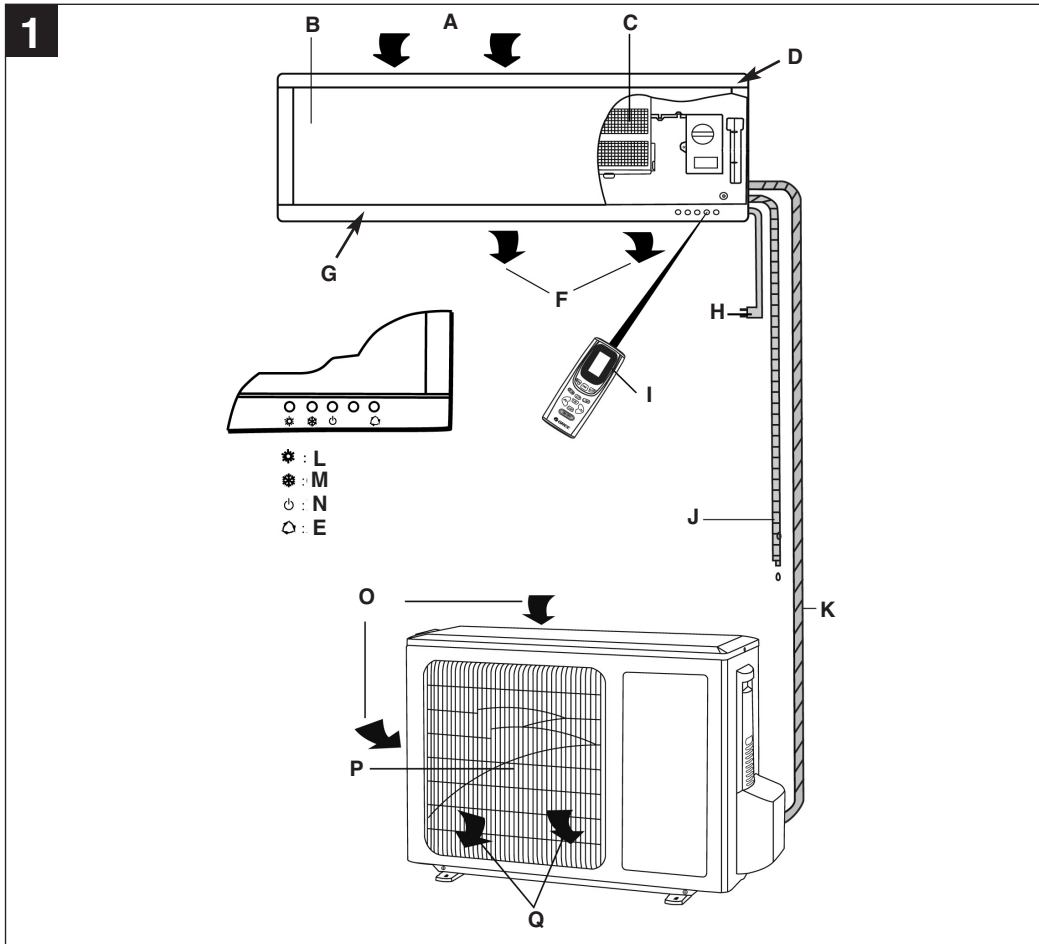

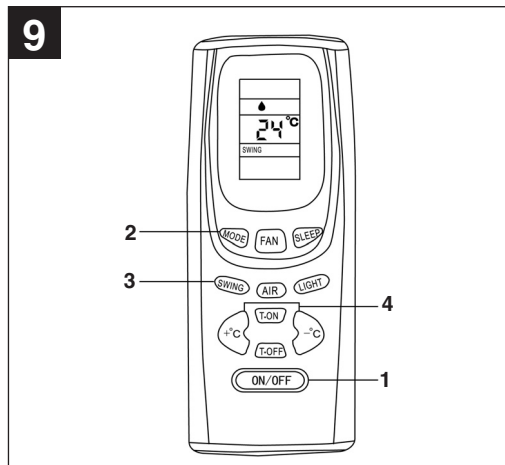
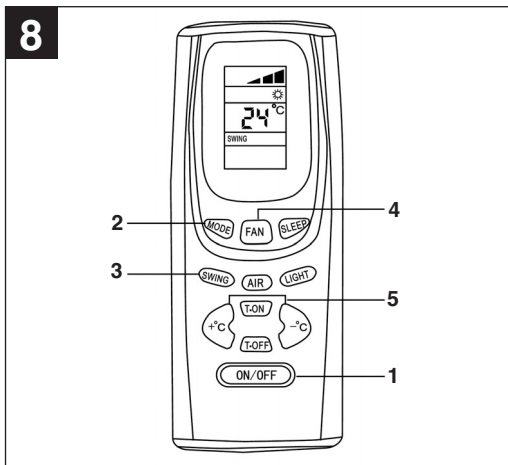
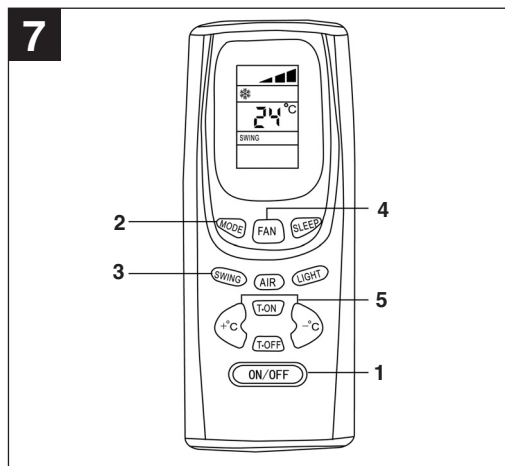
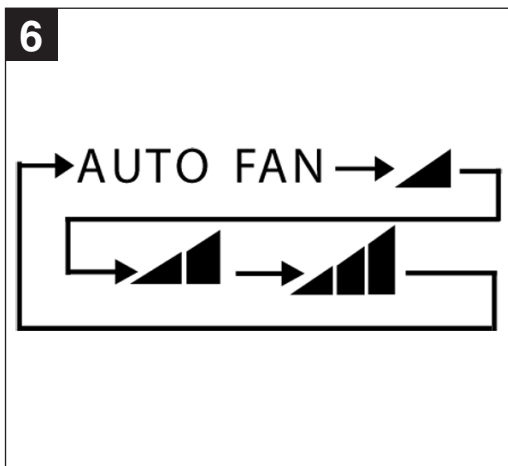
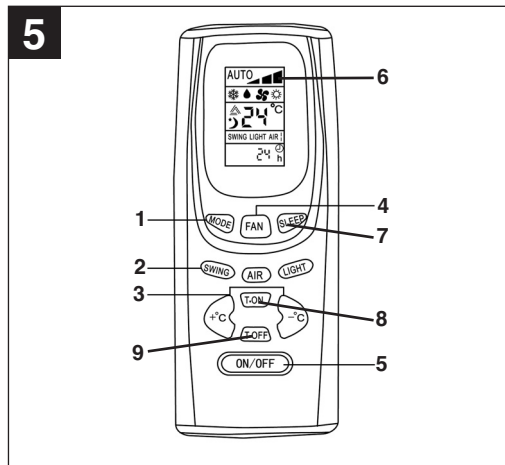
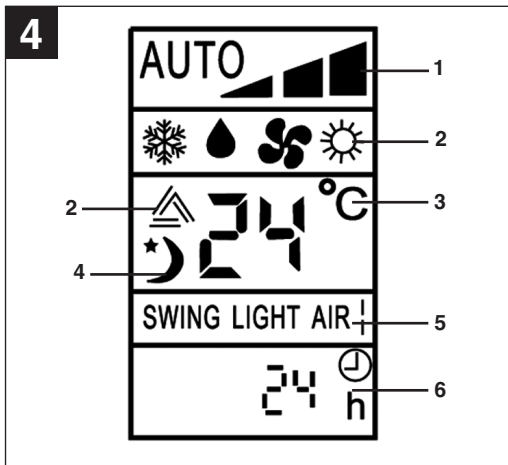

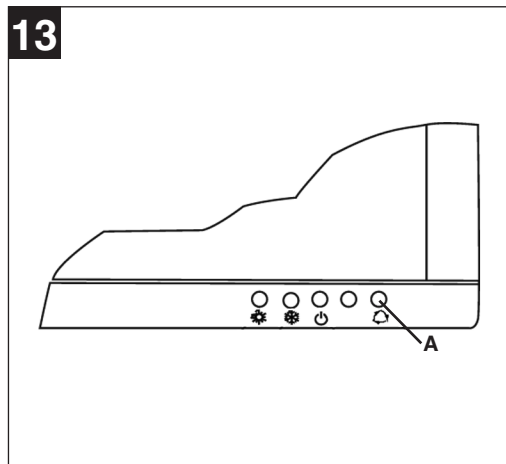
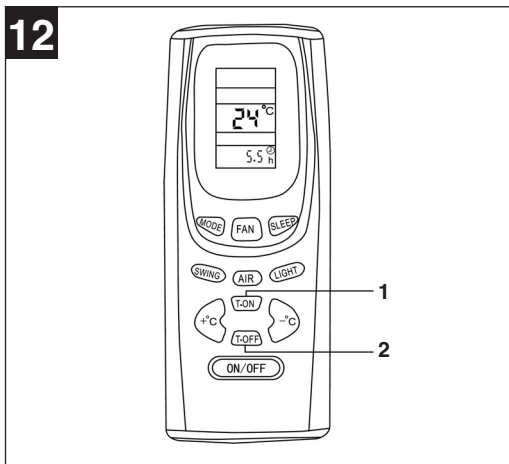
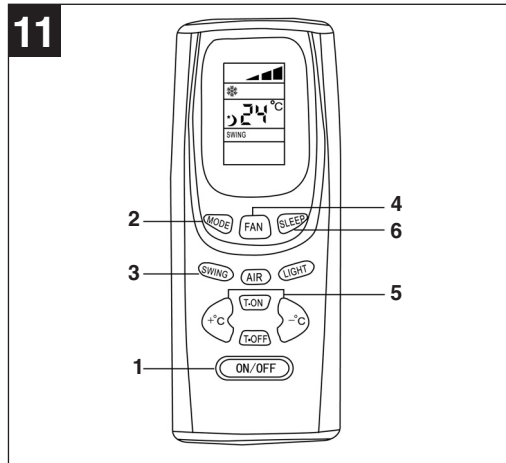
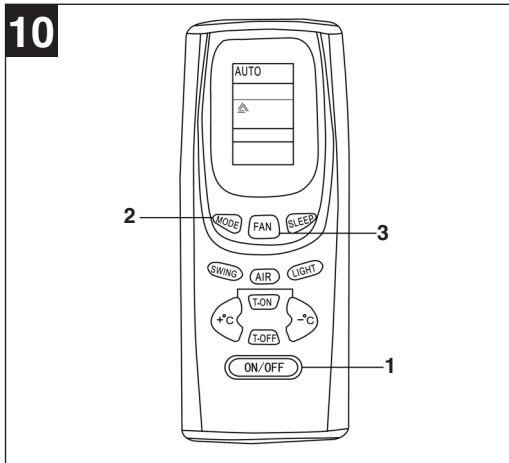

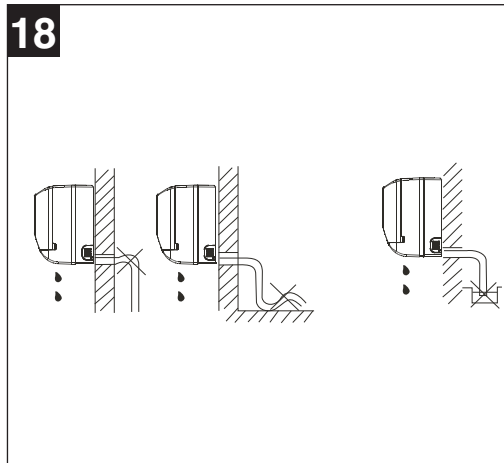
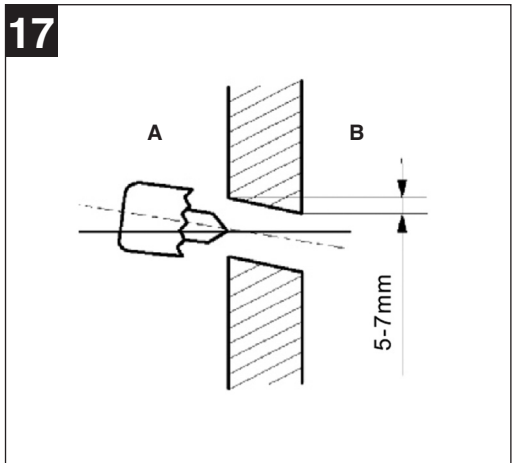
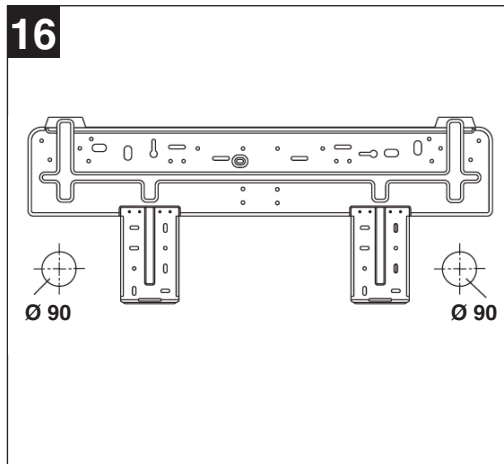
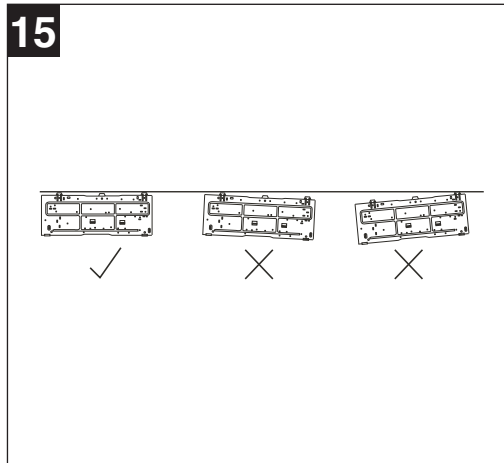
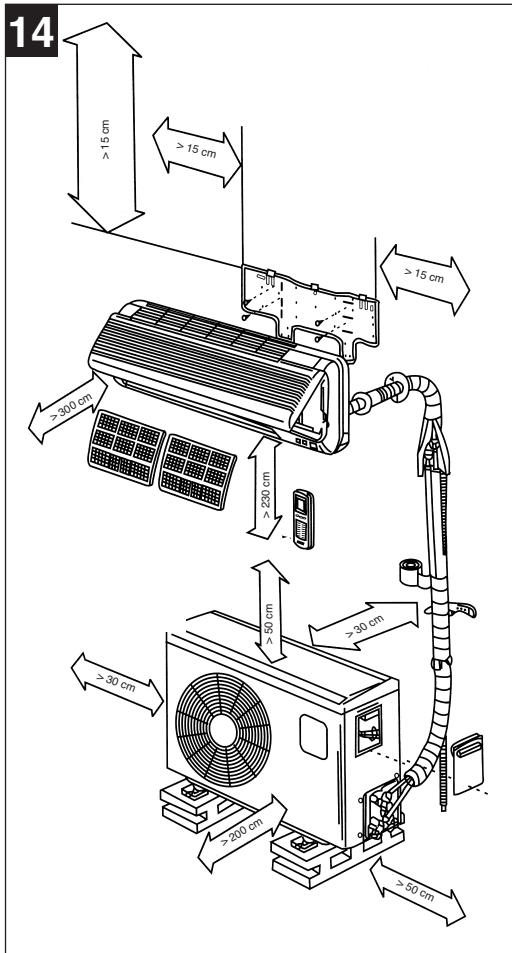

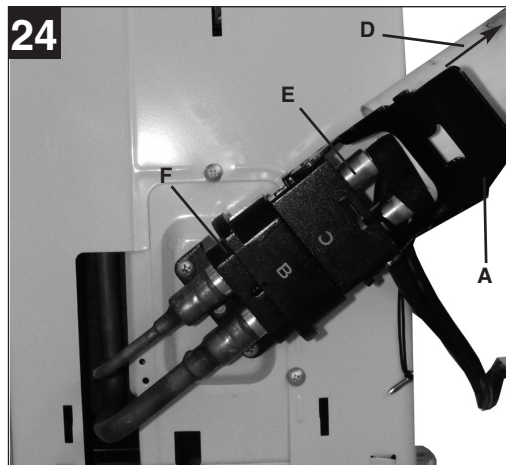
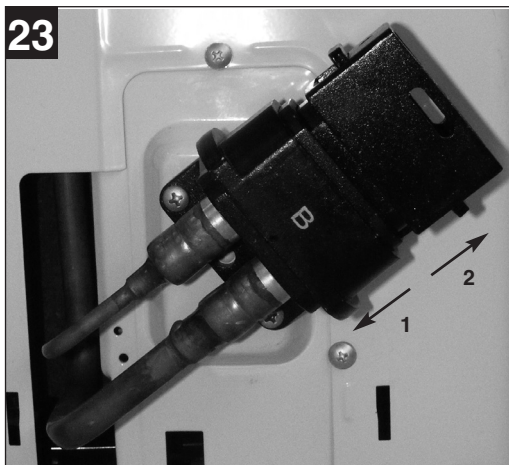
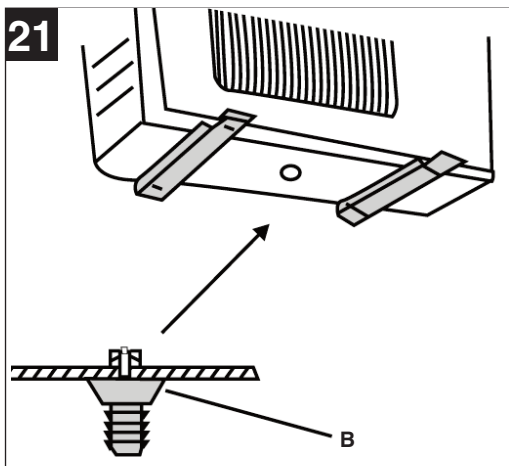
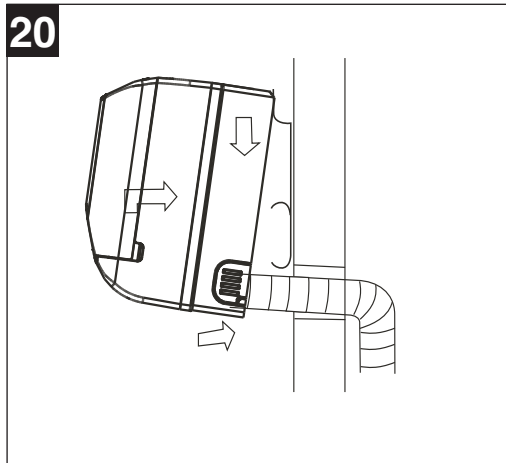
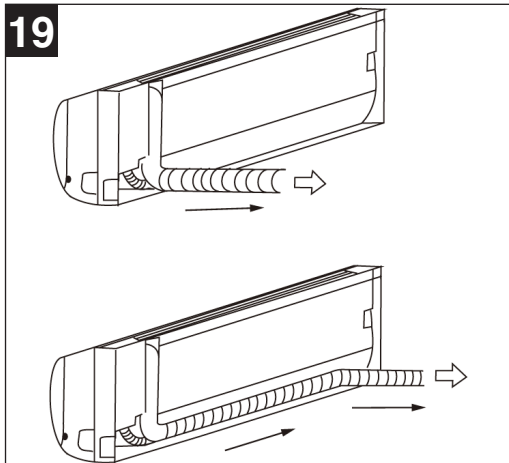

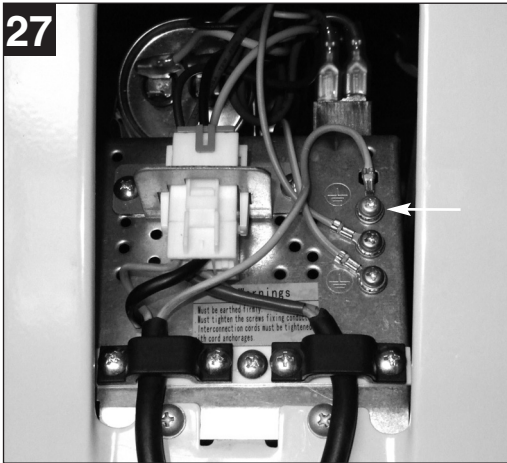
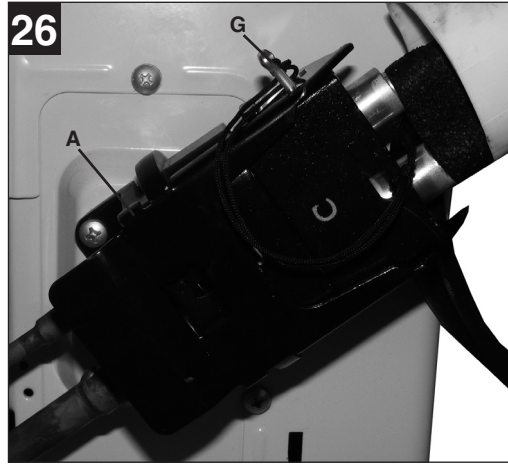
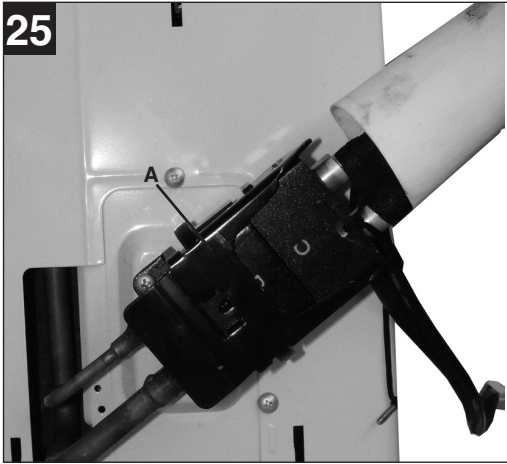

**GB**

## Table of contents

1. Safety instructions
2. Items supplied
3. Technical data
4. Intended use
5. Description of parts
6. Setting up the remote control
7. Functional description of the remote control
8. Indoor device settings
9. Cleaning notes
10. General notes
11. Troubleshooting
12. Installation accessories
13. Installation instructions
14. Ordering replacements parts



**⚠ Important!**

When using the equipment, a few safety precautions must be observed to avoid injuries and damage. Please read the complete operating instructions and safety regulations with due care. Keep this manual in a safe place, so that the information is available at all times. If you give the equipment to any other person, hand over these operating instructions and safety regulations as well. We cannot accept any liability for damage or accidents which arise due to a failure to follow these instructions and the safety instructions.

**1. Safety instructions**

- Read the safety instructions before you start to use the device.
- These points set out extremely important precautionary measures that you must comply with.
- Keep the Operating Instructions in a safe place once you have read them.
- Check that the drainage line is correctly connected. If not, water will escape.
- **Warning!**  
Do not extend the cable and never use multiple plugs. A poor electrical connection, poor insulation or voltage which is higher than permitted can cause fire.
- **Remove all dirt from the power plug and plug it in firmly. Soiled plugs can cause fire or an electric shock.**
- **Warning!**
- Never pull out the plug while the device is in use.
- Never permit cool air to be blown directly at you for any lengthy period of time.
- In the event of any abnormalities (e.g. smell of burning), immediately switch off the device and pull the plug. Contact your service partner.
- Never poke fingers or sticks in the air inlet and outlet vents.
- Never attempt to repair the air conditioner yourself. Always contact your service partner if it requires repair.
- Never pull the plug out by pulling on the cable. Hold the plug firmly and pull it out of the plug socket, otherwise there is a risk of damaging the cable.
- Always switch off the device and pull the plug before you start to clean it.
- Never actuate any switches with wet hands.
- Never clean the air conditioner with water.
- Never place any plants or animals under a location to which cool air flows as this could have an undesirable affect on them.
- Never use combustible cleaning agents as these could cause a fire or deformation.
- If the air conditioner is to be used in conjunction with other heaters, the air should be refreshed periodically, otherwise there is a risk of lack of oxygen.
- Never use the device for any other purpose than the intended use. Never place food, precision instruments, plants, animals, paint, etc. on the device.
- Never hold any burning objects close to the device if they could be directly affected by the emitted air.
- Always pull out the power plug if the device is not going to be used for any lengthy period of time. Collections of dust can cause fire.
- Never step onto the outdoor device and never place anything on it.
- Never use an unsteady or rusty base.
- Never allow the device to run for too long with the doors or windows open, or if the humidity is very high. If the air conditioner runs for a long time in cooling mode and the humidity is high (over 80%), condensed water may drip out of the device.
- Never stand on an unsteady base when you remove the device from the holder on the wall.
- Check that the condensation water can run off unhindered. Water damage can result if the condensation water cannot run off properly.
- Never touch any metal parts on the indoor device when removing the air filter. You may injure yourself.
- Never install the device in a room in which combustible gases can be emitted. Emitted gases may collect and cause an explosion.
- Always switch off the device and pull out the power plug during a storm. Electrical parts may get damaged.
- **Earthing connection!**  
The power cable (plug) comes with an earthing wire. Do not, therefore, change the plug.
- For electrical safety purposes we recommend that you install an earth-leakage circuit-breaker.
- Leave the electrical installation of the 230 V socket for the system to an authorized electrical contractor. Incorrect installation can lead to injury or damage to property.
- If you are not confident in being able to assemble the system, ask our customer service team or a refrigeration contractor of your choice to do the refrigeration part of the installation work. Incorrect installation can lead to injury or damage to property.
- Incorrect installation may cause injury or damage to the device.

**GB**

- Check the mains lead at regular intervals for signs of defects or damage. A damaged mains lead may only be replaced by an electrician or ISC GmbH in compliance with the relevant regulations.
- The equipment is not designed for installation in laundries.
- The equipment must be positioned in such a way that the mains plug is accessible at all times.
- The temperature in the cooling circuit may become very hot. For this reason keep all cables away from the copper lines.

**⚠ CAUTION!****Read all safety regulations and instructions.**

Any errors made in following the safety regulations and instructions may result in an electric shock, fire and/or serious injury.

**Keep all safety regulations and instructions in a safe place for future use.****Packaging:**

The unit is supplied in packaging to prevent it from being damaged in transit. The raw materials in this packaging can be reused or recycled.

**Tips on saving energy**

Only use the air conditioner when you really need to. Do not select too high a temperature for heating or too low a temperature for cooling. Select the "Sleep" function during the night.

Close all windows, doors and Venetian blinds in order to reduce incoming sunlight as far as possible.

**Principle of operation for cooling**

Heat is extracted from the air in the room by the air heat-exchanger (evaporator) in which the coolant circulates. This air is conveyed to the outside air heat-exchanger (condenser).

This gives off heat to the outdoor air. Electrical energy is required for this. In certain circumstances condensation may form on the evaporator on the indoor unit, which will be removed by the condensation hose.

**2. Items supplied****Split 900 Flat EQ C+H**

- 1 indoor device (box 1, art. no. 23.654.54)
- 1 outdoor device (box 2, art. no. 23.654.55)
- 1 set of installation accessories (for details, see page 16)

**Split 1200 Flat EQ C+H**

- 1 indoor device (box 1, art. no. 23.654.56)
- 1 outdoor device (box 2, art. no. 23.654.57)
- 1 set of installation accessories (for details, see page 16)

**3. Technical data****Split 900 Flat EQ C+H**

Cooling capacity	2600 watts
Heating capacity	2800 watts
Energy efficiency	A (EER 3.25/COP 3.26)
Air capacity	450 m <sup>3</sup> /h
Absorbed humidity (30°C/80% RH)	1.0 l/h
Timer	24 h
Operating voltage	230 V ~ 50 Hz
Socket fusing	10 A
Nominal power consumption, cooling	960 watts
Nominal current consumption, cooling	4.17 A
Nominal power consumption, heating	1120 watts
Nominal current consumption, heating	4.87 A
Compressor	Rotary piston
Compressor starting current	17 A
Outdoor operating temperature	0 - +43 °C
Indoor operating temperature	+16 - +30°C
Fluid line Ø A	6.35 mm
Suction pipe Ø A	12.7 mm
Length of refrigerant line supplied	4 m
Length of refrigerant line, max.	10 m
Max. difference in height between indoor/outdoor device	5 m
Refrigerant	R 410 A
Refrigerant filling capacity	1100 g
Refrigerant refill quantity from 5 m	20 g/m
Sound pressure level	
Inside	≤ 38 dB (A)
Outside	≤ 53 dB (A)
Dimension Inside	100,5 x 29 x 15 cm
Dimension Outside	84,8 x 54 x 32 cm
Weight Inside	16 kg
Weight Outside	40 kg

**Split 1200 Flat EQ C+H**

Cooling capacity	3500 watts
Heating capacity	3700 watts
Energy efficiency	A (EER 3.21/COP 3.30)

Air capacity	500 m <sup>3</sup> /h
Absorbed humidity (30°C/80% RH)	1.0 l/h
Timer	24 h
Operating voltage	230 V ~ 50 Hz
Socket fusing	16 A
Nominal power consumption, cooling	1440 watts
Nominal current consumption, cooling	6.26 A
Nominal power consumption, heating	1440 watts
Nominal current consumption, heating	6.26 A
Compressor	Rotary piston
Compressor starting current	24 A
Outdoor operating temperature	0 - +43 °C
Indoor operating temperature	+16 - +30°C
Fluid line Ø A	6,35 mm
Suction pipe Ø A	12,7 mm
Length of refrigerant line supplied	4 m
Length of refrigerant line, max.	10 m
Max. difference in height between indoor/outdoor device	5 m
Refrigerant	R 410 A
Refrigerant filling capacity	1400 g
Refrigerant refill quantity from 5 m	20 g/m
Sound pressure level	
Inside	≤ 40 dB (A)
Outside	≤ 54 dB (A)
Dimension Inside	100,5 x 29 x 15 cm
Dimension Outside	84,8 x 54 x 32 cm
Weight Inside	16 kg
Weight Outside	40 kg

**Note:**

The specified capacities and performances are based on the following conditions (EN 14511):

**Cooling:**

Air temperature at the inlet on the indoor device: 27°C for dry thermometer bulb (DB), 19°C for wet thermometer bulb (WB). Outdoor air temperature: 35°C for dry thermometer bulb (DB), 24°C for wet thermometer bulb (WB).

**Heating:**

Air temperature at the inlet on the indoor device: 20°C for dry thermometer bulb (DB), 15°C for wet thermometer bulb (WB). Outdoor air temperature: 7°C for dry thermometer bulb (DB), 6°C for wet thermometer bulb (WB).

**Temperature ranges:****Cooling**

Room temperature	16°C ~ 30°C
Outdoor temperature	18°C ~ 43°C

**Heating**

Room temperature	16°C ~ 30°C
Outdoor temperature	0°C ~ 24°C

**Dehumidifying**

Room temperature	16°C ~ 30°C
Outdoor temperature	18°C ~ 43°C

**Notes:**

1. For health reasons the room temperature should be no more than 5 – 6°C below the outdoor temperature in cooling mode.
2. The perfect performance of the system is achieved within the temperature ranges shown in the table.
3. If the air conditioning system is operated below the temperature range shown above, protection functions may be activated in certain circumstances which will cause the device to operate abnormally.
4. If the air conditioner is operated in a relative humidity level of over 80%, condensation may be deposited on the top of the system which will then drip on to the floor. In this case set the horizontal air flap to its maximum angle (perpendicular to the floor) and set the FAN to "HIGH".

**4. Intended use**

The Split 900 Flat EQ C+H air-conditioning system is only designed for air-conditioning privately used dry rooms with a maximum room volume of 80 m<sup>3</sup> (Split 1200 Flat EQ C+H is suitable for a maximum room volume of 110 m<sup>3</sup>). The room volume depends on the local conditions. Large window areas, additional heat sources (PC, television, people, etc.), poor wall insulation, etc. serve to reduce this room volume.

The machine is to be used only for its prescribed purpose. Any other use is deemed to be a case of misuse. The user / operator and not the manufacturer will be liable for any damage or injuries of any kind caused as a result of this.

Please note that our equipment has not been designed for use in commercial, trade or industrial

**GB**

applications. Our warranty will be voided if the machine is used in commercial, trade or industrial businesses or for equivalent purposes.

## 5. Description of parts (Fig. 1)

- A: Air inlet
- B: Cover
- C: Air filter
- D: Housing
- E: Emergency switch for automatic operation
- F: Air outlet
- G: Slat
- H: Power cable
- I: Infrared remote control
- J: Condensation water hose
- K: Refrigerant line
- L: Heating
- M: Cooling/dehumidifying
- N: Operating display
- O: Air inlet
- P: Air outlet grille
- Q: Air outlet

## 6. Setting up the remote control (Fig. 2)

### Insert batteries

1. Open the battery compartment cover.
2. Insert two new batteries. Be sure to observe the correct polarity (+/-) of the batteries.
3. Close the battery compartment cover.

### Notes

- The radio signal has a range of approx. 8 m.
- Use two alkali batteries, type R03 AAA (1.5 V).
- Always replace both batteries at once when you can no longer see the LCD display.
- Never use a combination of new and used batteries.
- Never use a battery type other than the specified one.
- If the remote control is not used for a lengthy period of time, remove the batteries to prevent them leaking.
- The service life of the batteries if the remote control is used normally is approximately 12 months.
- Dispose of spent batteries properly.

### Notes

Keep the remote control approximately 1 m from television sets or other electrical appliances. Direct sunlight may considerably reduce the range of the

remote control.

Objects between the remote control and the IR receiver which can impede reception of the signal must be avoided. Handle the remote control with care. Do not drop it, keep it away from heat and moisture so as not to damage the remote control.

## 7. Functional description of the remote control

### Key assignment (Fig. 3)

- 1 "Mode" (operating mode) key
  - 2 "Fan" (fan speed) key
  - 3 "Sleep" (sleep function) key
  - 4 "Swing" (automatic, horizontal slat adjustment) key
  - 5 "+ °C" (temperature increase) key
  - 6 "- °C" (temperature decrease) key
  - 7 "T-ON" (device ON timer) key
  - 8 "T-OFF" (device OFF timer) key
  - 9 "ON-OFF" (device ON/OFF) key
- "AIR" and "LIGHT" keys are not assigned

### Display (Fig. 4)

- 1 "Fan speed" display
- 2 "Mode" display
- 3 "Temperature" display
- 4 "Sleep mode" display
- 5 "Slat adjustment" display
- 6 "Timer" display

## Remote control brief description (Fig. 5-6)

### 1 "Mode" (operating mode) key

This key is used to select one of the available operating modes. The operating mode changes in the following sequence per key press:

**Automatic -> Cooling -> Dehumidifying -> Fan -> Heating**

### 2 "Swing" (automatic, horizontal slat adjustment) key

Press this key once for electric, horizontal slat adjustment. The air flow is adjusted upwards/downwards.

Press the key twice to lock the slats in their current position.

### 3 "+ °C" (temperature increase) and "- °C" (temperature decrease) keys

Press the "+ °C" key once to increase the set temperature by 1°C. Press the "- °C" key once to

decrease the set temperature by 1°C.  
The temperature can be set from 16°C to 30°C on the remote control via the "Cooling", "Dehumidifying" and "Heating" operating modes.  
The temperature cannot be set in the "Automatic" and "Fan" modes.

#### 4 "Fan" (fan speed) key

The fan speed changes in the following sequence per key press:

**Automatic -> Slow -> Medium -> Fast**

#### 5 "ON-OFF" (device ON/OFF) key

This key is pressed to switch the device on and off.

#### 6 LCD display

All settings are displayed.

#### 7 "Sleep" (sleep function) key

Press this key once to activate the sleep function.  
Press the key twice to switch the function back off.

#### 8 "T-ON" (device ON timer) key

Press this key to automatically switch on the device within a 0.5 and 24 hour range.

#### 9 "T-OFF" (device OFF timer) key

Press this key to automatically switch off the device within a 0.5 and 24 hour range.

#### Note:

The "AIR" and "LIGHT" keys are not assigned and do not influence the device when pressed.

## Operating modes

### A) Cooling mode (Fig. 7)

1. Press the "ON/OFF" key to switch on the device.
2. Press the "MODE" key until the "Cooling" mode icon appears in the display.
3. Press the "Swing" key. The air flow is adjusted upwards/downwards. Press the key twice to lock the slats in their current position.
4. Press the "FAN" key to select the fan speed:  
Automatic -> Slow -> Medium -> Fast
5. Press the "+°C" or "-°C" key to set the desired temperature.

#### Notes!

- The cooling mode will only work if the room temperature set is lower than the current room temperature. When the set room temperature is reached, the outdoor compressor stops. The centrifugal fan of the indoor device circulates the air in the room.

- The set room temperature should not be more than 5°C below the outdoor temperature (example: outdoor temperature 30°C, ideal room temperature 25°C).
- The room temperature can be set between 16°C and 30°C with the remote control.
- The higher the outdoor temperature, the higher the attainable indoor temperature

### B) Heating mode (Abb. 8)

1. Press the "ON/OFF" key to switch on the device.
2. Press the "MODE" key until the "Heating" mode icon appears in the display.
3. Press the "Swing" key. The air flow is adjusted upwards/downwards. Press the key twice to lock the slats in their current position.
4. Press the "FAN" key to select the fan speed:  
Automatic -> Slow -> Medium -> Fast
5. Press the "+°C" or "-°C" key to set the desired temperature.

#### Notes!

- The heating mode will only work if the room temperature set is higher than the current room temperature. When the set room temperature is reached, the outdoor compressor stops. The centrifugal fan of the indoor device circulates the air in the room.
- The room temperature can be set between 16°C and 30°C with the remote control.
- The attainable room temperature is a factor of local conditions and the outdoor temperature. The cooler the outdoor temperature, the lower the attainable room temperature.

### C) Dehumidifying mode (Abb. 9)

1. Press the "ON/OFF" key to switch on the device.
2. Press the "MODE" key until the "Dehumidifying" mode icon appears in the display.
3. Press the "Swing" key. The air flow is adjusted upwards/downwards. Press the key twice to lock the slats in their current position.
4. Press the "+°C" or "-°C" key to set the desired temperature.

#### Notes!

- The "Dehumidifying" mode only works if the difference between the set room temperature and the current room temperature is within +/- 2°C.
- If the room temperature set for the "Dehumidifying" mode is more than 2°C higher than the current room temperature, the compressor stops along with the fan in the outdoor device. The centrifugal fan of the indoor device is also switched off.

**GB**

- If the room temperature set for the "Dehumidifying" mode is more than 2°C below the current room temperature, the device runs in cooling mode.
- The room temperature can be set between 16°C and 30°C with the remote control.

**D) Automatic mode (Fig. 10)**

1. Press the "ON/OFF" key to switch on the device.
2. Press the "MODE" key until the "Automatic" mode icon appears in the display. The device automatically switches to cooling, fan or heating mode, depending on the current room temperature.
3. Press the "FAN" key to select the fan speed: Automatic -> Slow -> Medium -> Fast

**Notes!**

- When "Automatic" mode is selected, the room temperature is fixed at 25°C for cooling and 20°C for heating. These temperatures cannot be changed.
- When the current room temperature is between 23°C and 26°C in "Automatic" mode, the device runs as a fan without the effect of heating or cooling.
- When the current room temperature is greater than 26°C in "Automatic" mode, the device runs with a cooling effect.
- When the current room temperature is below 22°C in "Automatic" mode, the device runs with a heating effect.

**E) Sleep function (Fig. 11)**

1. Press the "ON/OFF" key to switch on the device.
2. Press the "MODE" key until the "Cooling", "Dehumidifying" or "Heating" mode icon appears in the display.
3. Press the "Swing" key. The air flow is adjusted upwards/downwards. Press the key twice to lock the slats in their current position.
4. Press the "FAN" key to select the fan speed: Automatic -> Slow -> Medium -> Fast
5. Press the "+°C" or "-°C" key to set the desired temperature.
6. Press the "Sleep" key to activate the sleep function.

**Notes!**

- If the cooling or dehumidifying mode is set in conjunction with the sleep function, the set room temperature increases (1°C during the first hour and 2°C during the second hour) in order to prevent overcooling.
- If the heating mode is set in conjunction with the sleep function, the set room temperature decreases (1°C during the first hour and 2°C

during the second hour) in order to prevent overheating.

**F) Timer settings (for automatically switching the device on/off) (Fig. 12)****1. "T-ON" (device ON timer) key**

This key is pressed to automatically switch on the unit. The only requirement is that the unit be connected to a power supply. Each time the key is pressed, the time setting changes by an increment of 0.5 hours within a 0.5 and 24 hour range. To switch the "Device ON timer" back off, press the key again after "24h" is displayed or switch off the device by pressing the "ON/OFF" key.

**2. "T-OFF" (device OFF timer) key**

This key is pressed to automatically switch off the unit. The only requirement is that the unit be in operation. Each time the key is pressed, the time setting changes by an increment of 0.5 hours within a 0.5 and 24 hour range. To switch the "Device OFF timer" back off, press the key again after "24h" is displayed or switch off the device by pressing the "ON/OFF" key.

**8. Indoor device settings****Setting the vertical air flow direction**

The left-hand and right-hand side flow directions can be adjusted manually. Perform these adjustments before you start the device because once it has been started the slats vibrate and there is a risk of your fingers getting caught.

**Remote control fails to work (emergency operation) (Fig. 13)**

If the remote control fails to work (empty batteries or malfunction), use the emergency switch (A).

- The device is off: After the emergency stop switch has been pressed the device switches to automatic mode. The slatadjuster also operates in automatic mode.
- The device is on: The device switches off if the emergency switch is pressed.

**9. Cleaning notes****Important!**

Switch the device off and pull the mains plug each time before cleaning.



**Note!**

The time intervals at which the device should be cleaned are a factor of the area of installation. The time intervals listed below should be maintained in most cases.

Keep the outdoor device and the area around the outdoor device clean. Regularly remove leaves, etc. which can collect around the outdoor device.

**Cleaning the housing of the indoor device**

- Clean the housing of the indoor device using only a soft, wet cloth when necessary.
- In order to avoid damaging the housing and electronics, avoid the use of gasoline, thinners, scouring powder, cleaners and the like when cleaning.

**Cleaning the air filters of the indoor device**

Make sure that the air filters are clean! Soiled air filters reduce the air output of the device. The air filters of the indoor device should be checked and, if necessary, cleaned on a monthly basis.

1. Pull on the recess at the right and left by the panel and open. The opening angle is limited by the lateral guides.
2. Carefully pull the panel up out of the brackets and fold the brackets back down.
3. Now lift the panel a little and remove the air filters below.
4. Carefully vacuum off the air filters or wash them using a neutral soap solution. Note that the water temperature must not exceed 45°C, as the air filters would then change in color and could become distorted. Let the air filters dry in the shade.
5. To reinstall the air filters in the indoor device, lift the panel a little and reinsert.
6. Lower the panel back down until it latches into the panel brackets on the inner housing. Close the panel. Replace the air filters once annually. Replacement air filters can be obtained from your service partner.

**Cleaning the heat exchanger of the indoor device**

The heat exchanger must be cleaned at least once annually. To do this, remove the air filters from the indoor device as described above.

- Using a vacuum cleaner or a long-bristled brush, carefully remove any dirt deposits on the heat exchanger; this will avoid damaging the heat exchanger fins. A damaged heat exchanger will lead to higher operating costs.
- Take steps to ensure that you do not injure yourself on the fin edges!

**10. General notes****After pressing the start key the device is not started by the microprocessor for 3 minutes.**

This is not a fault, it is for the protection of the compressor. Please have a little patience.

**Crackling noises can be heard.**

This is not a fault. These tension noises are caused by the contraction and expansion of the front panel in response to temperature differences.

**There is an odd smell in the room.**

This is not a fault. The air conditioner also circulates the transpiration from the walls, carpets, smoke, furniture and clothing in the air.

**You can hear moving water.**

This is not a fault. The coolant in the air conditioner may have expanded.

**The air conditioner switches off during heat mode. Heat mode is not possible if the outdoor temperature is below approx. 0°C.**

The outdoor device freezes if the outdoor temperature is low (below approx. 0°C).

**Restarting after lengthy non-use**

If the air-conditioning system has not been used for a lengthy period, check the following before you switch it on:

1. there are no objects covering the outdoor or indoor unit.
2. the socket from which the unit is operated has been installed correctly
3. the air filters are clean

**Care precautions**

If the air conditioner is not going to be used for some period of time:

1. Let the fans run for 6 hours to allow the device to completely dry out. Set the highest possible temperature level while the fans are running.
2. Switch off the device and pull the power plug.
3. Clean the air filters and housing parts.
4. Remove all dirt from the outdoor unit.
5. Take the batteries out of the remote control.

**GB**

## 11. Troubleshooting

### Device does not start. Check the following:

1. Is voltage present at the plug socket outlet?
2. Check the plug fuse!
3. Is the timer set?

### The device does not provide satisfactory cooling!

#### Check the following:

1. Has an appropriate temperature been set?
2. Is the air filter soiled? Clean and fit back in place.
3. Are the inlets and outlets on the outdoor device blocked?
4. Has the sleep mode been set during the day?
5. Are the connections between the indoor and outdoor device adequately sealed? There may not be enough coolant? If so, please contact your service company.

### In the event of a power failure, check the following:

Press the ON/OFF key after a power failure. If the problems remain after checking through the above points, switch off the device and contact your service company.

## 12. Installation accessories

Please check that all the installation accessories have been supplied prior to carrying out the installation work.

- 1 mounting plate for the indoor device
- 1 infrared remote control
- 2 batteries (type AAA, 1.5 V)
- 10 screws (4.2 x 25)
- 1 condensed water hose (L = 2 m)
- 1 sealing compound
- 1 wall hole cap
- 5 cable ties

## 13. Installation instructions (Fig. 14):

### Check that the actual mains voltage is the same as the mains voltage specified on the rating plate.

- Important. Make sure that there are no electric cables or other installations (for example water pipes) near the drill holes.
- Earth the outdoor device in accordance with current regulations.
- The device must have separate protection against short-circuits.

- Leave the electrical installation work (230 V socket-outlet) to a specialist contractor.
- Have all refrigeration installation work performed by a specialist contractor if you are not confident of doing this yourself.
- Incorrect installation can lead to injury or damage to property.
- Always wear ear muffs, goggles and work gloves when performing work of installation.

### Notes on electrical connection!

All electrical connection work (230 V socket-outlet) must be performed by a qualified electrician authorized to do so such work by the applicable electricity supply company. The system must have separate protection against short-circuits. Select a suitably large cable cross-section. The yellow/green wire is to be used as a protective conductor only and under no circumstances as a voltage carrying conductor. The fixed electrical connection of the device must be capable of being isolated from the mains power supply by a device with an isolating distance of at least 3 mm (e.g. circuit-breaker). Connect the electrical connections of the indoor and outdoor devices together first and then connect to the mains power supply. Check first that the entire system is voltage-free. Secure the system from being switched on again.

## A. Selecting the place of installation

### Indoor device

1. The openings for the inlet and outlet air must never be covered, otherwise the air will not be distributed throughout the entire room.
2. Install the indoor device in a location which ensures that the distance through the wall to the outdoor device is as short as possible.
3. Make sure that the drainage hose does not have any kinks or upward inclines when you connect it with the outside.
4. Do not select a location adjacent to a source of heat, high humidity or inflammable gas.
5. Select a location which is firm enough for installation so that the device is not subjected to vibrations.
6. Check that the device has been installed correctly and exactly.
7. Make sure that there is sufficient space available for later repair and service work.
8. The device should be installed at a distance of at least 1 m from all other electrical devices and installations, e.g. TV, radio, computer, etc.
9. Select a location for the device which is easily accessible so that the filter can be cleaned or



replaced without difficulty.

10. The maximum distance between the standard indoor unit and outdoor unit is 4 m. The maximum possible length of the refrigerant line is 10 m with a maximum height difference of 5 m.
11. Avoid direct sunlight.

#### Outdoor device

1. Select a location which avoids causing a nuisance to neighbours from noise and air emissions from device.
2. Select a location which is sufficiently well ventilated.
3. Never cover the air inlets and outlets.
4. The location must be sufficiently firm for installation and the prevention of vibrations.
5. There must be no risk presented by combustible gas or gas escaping as a result of corrosion.
6. Check that the device is installed in accordance with regulations.
7. It should be installed at least 20 cm above the expected snow line. Snow must not be allowed to get into the outdoor unit.
8. The wall for installation must be strong and capable of supporting the weight of the unit.
9. The device must not be exposed to strong gusts of wind.
10. Make sure that the device is well ventilated and kept free of dust. Avoid direct exposure to rain and sunlight.
11. Install on a firm base, avoiding excessive noise or vibrations.

#### Important:

**The following could cause malfunctions.**

**Check with your service company in order to prevent possible malfunctions at a later date.**

#### The following locations should be avoided for installation:

- A location where oil (machine oil) is stored.
- A location where there is a high salt content.
- A location with numerous sulphurous sources, e.g. spa zones.
- A location where radio transmitters or amplifier aerials, welding equipment or medical equipment are in use.
- A location where the outdoor device is exposed to direct sunlight. If necessary the device must be protected with a sun-shade. Such a sun-shade must not interfere with the air flow, however.
- A location in the vicinity of heat or steam generators.
- A location which is heavily exposed to dust.

- A location to which the general public have access.
- A location with any other unusual characteristics.

#### Important!

- The direction in which the air is blown should correspond with the prevailing direction of the wind.
- Never install in locations exposed to aggressive air.
- Comply with all specified minimum distances (see Important notes on installation).
- The indoor and outdoor devices may only be installed if they are in a horizontal position measured using a spirit level. Check this after you have completed the installation work.
- Do not kink or compressed the refrigerant lines.
- All the refrigerant lines, including connectors and valves must be fitted with diffusion-resistant heat insulation.
- Do not remove the protective caps from the refrigerant lines / connections on the device until immediately before you connect them.
- Open refrigerant lines must be protected from the ingress of moisture by suitable caps or adhesive tapes.

## B. Installing the indoor device

It is imperative that you comply with the installation instructions.

### 1. Before you start installation

- Select the location for the indoor device (follow the previous notes on selecting the location for installation).
- Check that the available mains voltage is the same as the voltage specified on the rating plate.
- Fit appropriate insulation, supplied by the customer, to the coolant tubes.

### 2. Fitting the mounting plate (Fig. 15/16)

- The mounting plate for the indoor device must be fitted horizontally to the wall. In doing so, it is imperative that you comply with all specified distances. Mark and drill the holes for fastening the mounting plate, and then firmly fasten with dowels and screws. In order to prevent vibrations on the indoor device, make sure that there are no gaps between the wall and the mounting plate.

### 3. Drilling holes through the walls (Fig. 16/17)

- Drill the hole through the wall for the lines/hoses using a 90 mm drill bit, drilling from the inside (A) to the outside (B) at an angle downwards of

**GB**

approx. 5°. The ideal positions of the holes through the walls are shown in Figure 16.

#### 4. Fitting the condensation drain hose (Fig. 18)

- The hose is fitted at the factory. The second connection port is sealed with a rubber bung.
- The condensation drain hose can be fitted on either the left or right of the two connection ports on the rear panel. The connection port that is not needed must be sealed tightly with the rubber bung. Otherwise the condensation can cause damage.
- The drainage water hose must be run to the outside with a downhill gradient. It is imperative that there are no bends or kinks. The end of the drainage hose must not be situated in a container of any kind in which water can collect. Any water held back in the drainage water hose could lead to water damage.
- Slide the additional drainage hose onto the ports on the drainage hose already fixed to the indoor device. Secure the connection with adhesive tape. Ensure that the connection is properly sealed.

#### Notes:

- Route the refrigerant lines from the indoor device to the outdoor device.
  - The package of lines/hoses is to be laid between the housing of the indoor device and the wall.
5. Feed the package of lines/hoses through the hole in the wall (Fig. 19).
  6. Attach the indoor device to the mounting plate. The top hook on the mounting plate must be securely attached to the rear of the indoor device. After you have completed the installation work, press the indoor device into the bottom mount (Fig. 20).

### C. Mounting the outdoor device

It is imperative that you follow the installation instructions.

#### 1. Before you start installation

- Select the location for installation (follow the previous notes on selecting the location).
- Check that the available mains voltage is the same as the voltage specified on the rating plate.
- The maximum possible distance between the indoor and the outdoor device using the supplied accessories is 4 m.
- If the outdoor device is higher than the indoor device, make sure that a curve is made in the coolant tube which is lower than the bottom edge

of the indoor device.

- Secure the condensation drain (B) to the base of the outdoor device. Drain the water generated when the system is in heating mode through a hose (Fig. 21).

#### 2. Installing the outdoor device

- The outdoor device can be fastened to the ground or to a wall bracket (e.g. special accessory Art. No. 23.651.57) with dowels and screws. To do so, use the holes on the device.

#### 3. Connecting the refrigerant line to the outdoor device

#### Notes:

- Have all service work performed by a specialist firm only. Contact our service partner.
- If ever the voltage carrying cable between the indoor device and the outdoor device should be damaged, contact a specialist firm.
- If the power cable should ever be damaged, have it replaced by an electrician.
  - a) The length of the coolant tube is 4 meters.
  - b) If the outdoor device is higher than the indoor device, a curve will be required in the coolant tube which is positioned below the height of the indoor device.

1. **Fig. 22:** Unscrew the connection protective cover.
2. **Fig. 23:** Push the plug fastening (B) to the rear (1) and pull off the guard for the connections (2). Keep the guard.
3. **Fig. 24:** Open the locking lever (A). Pull the wire insulation (D) back a little to prevent the insulation pushing on the pipe connections (E). Push the plug fastening (B) to the rear and slide the coupling part (C) firmly into the plug (F) until the plug fastening (C) snaps forwards. The plug (F) and coupling part (C) are now connected to each other.
4. **Fig. 25:** Close the locking lever (A). The plug and coupling part are now also secure to prevent their connection coming loose.
5. **Fig. 26:** Secure the locking lever (A) with the split pin (G).

**Note:** The photographs show the connection on the Split 900 Flat EQ C+H. On the Split 1200 Flat EQ C+H the plug part on the outdoor unit is horizontal. The procedure to connect the quick-release connectors is exactly the same as that described above. Please note that despite the existing quick-release connections the cables should only be connected to the outdoor device once so as to

maintain the best possible performance.

#### 4. Electrical connection of indoor and outdoor devices (Fig. 27)

- Follow all instructions and notes on electrical connection.
1. **Fig. 27:** Connect the exposed end of the connection cable which leads from the indoor device to the outdoor device to the plug-coupling system on the outdoor device. Secure the yellow-and-green core (PE) to the outdoor device. To secure the screw place a lock washer between the screw head and the cable lug. Tighten the screw until the cable lug rests tightly against the metal housing. The position on the outdoor device is marked with the PE symbol. Fasten the connector cable to the outdoor device using the cable clamp.
  2. Screw the connection guard back on the outdoor device.

Only replace the mains cable or the connection cable with a cable of the same type.

## 14. Ordering replacement parts

Please quote the following data when ordering replacement parts:

- Type of machine
- Article number of the machine
- Identification number of the machine
- Replacement part number of the part required

For our latest prices and information please go to [www.isc-gmbh.info](http://www.isc-gmbh.info)



## Konformitätserklärung

ISC-GmbH · Eschenstraße 6 · D-94405 Landau/Isar

**D** erklärt folgende Konformität gemäß EU-Richtlinie und Normen für Artikel  
**GB** declares conformity with the EU Directive and standards marked below for the article  
**F** déclare la conformité suivante selon la directive CE et les normes concernant l'article  
**NL** verklaart de volgende conformiteit in overeenstemming met de EU-richtlijn en normen voor het artikel  
**E** declara la siguiente conformidad a tenor de la directiva y normas de la UE para el artículo  
**P** declara a seguinte conformidade de acordo com a directiva CE e normas para o artigo  
**S** förklarar följande överensstämmelse enl. EU-direktiv och standarder för artikeln  
**FIN** ilmoittaa seuraavaa Euroopan unionin direktiivien ja normien mukaista yhdenmukaisuutta tuotteelle  
**N** erklærer herved følgende samsvar med EU-direktiv og standarder for artikkel  
**HR** заявляє о соответствии товара следующим директивам и нормам EC  
**IS** izjavljuje sljedeću uskladenost s odredbama i normama EU za artikl.  
**RO** declară următoarea conformitate cu linia directoare CE și normele valabile pentru articolul.  
**TR** ürün ile ilgili olarak AB Yönetmelikleri ve Normları gereğince aşağıdaki uygunluk açıklama masını sunar.  
**GR** δηλώνει την ακόλουθη συμφώνία σύμφωνα με την Οδηγία ΕΕ και τα πρότυπα για το προϊόν

**I** dichiara la seguente conformità secondo la direttiva UE e le norme per l'articolo  
**DK** attesterer følgende overensstemmelse i henhold til EU-direktiv og standarder for produkt  
**CZ** prohlašuje následující shodu podle směrnice EU a norem pro výrobek.  
**H** a következő konformitást jelenti ki a termékerekre vonatkozó EU-irányvonalak és normák szerint  
**SL** pojasnjuje sledečo skladnost po smernici EU in normah za artikel.  
**PL** deklaruje zgodność wymienionego poniżej artykułu z następującymi normami na podstawie dyrektywy WE.  
**SK** vydáva nasledujúce prehlásenie o zhode podľa smernice EÚ a noriem pre výrobok.  
**BG** декларира следното съответствие съгласно директивите и нормите на ЕС за продукта.  
**UKR** заявляє про відповідність згідно з Директивою ЄС та стандартами, чинними для даного товару  
**ES** deklareerib vastavuse järgnevalele EL direktiivi dele ja normidele  
**LT** deklaruoja atitiktį pagal ES direktyvas ir normas straipsniui  
**HR** izjavljuje sledeći konformitet u skladu s odredbom EZ i normama za artikl  
**LV** Atbilstības sertifikāts apliecina zemāk minēto preču atbilstību ES direktīvām un standartiem  
**IS** Samræmisýfirlýsing staðfestir eftirfarandi samræmi samkvæmt reglum Evrópubandalagsins og stöðlum fyrir vörur

## Klima-Splitanlage Split 900 Flat EQ C+H

- |                                                 |                                                 |
|-------------------------------------------------|-------------------------------------------------|
| <input type="checkbox"/> 98/37/EG               | <input type="checkbox"/> 87/404/EWG             |
| <input checked="" type="checkbox"/> 2006/95/EG  | <input type="checkbox"/> R&TTED 1999/5/EG       |
| <input type="checkbox"/> 97/23/EG               | <input type="checkbox"/> 2000/14/EG_2005/88/EG: |
| <input checked="" type="checkbox"/> 2004/108/EG | <input type="checkbox"/> 95/54/EG:              |
| <input type="checkbox"/> 90/396/EWG             | <input type="checkbox"/> 97/68/EG:              |
| <input type="checkbox"/> 89/686/EWG             |                                                 |

**EN 60335-1; EN 60335-2-40; EN 50366; EN 55014-1; EN 55014-2;  
EN 55022; EN 61000-3-2; EN 61000-3-3**

Landau/Isar, den 07.12.2007

  
Weichselgartner  
General-Manager

  
Wong  
Product-Management

Art.-Nr.: 23.658.20 I.-Nr.: 01017  
Subject to change without notice

Archivierung: 2365820-36-4155050-07



## Konformitätserklärung

ISC-GmbH · Eschenstraße 6 · D-94405 Landau/Isar

**D** erklärt folgende Konformität gemäß EU-Richtlinie und Normen für Artikel  
**GB** declares conformity with the EU Directive and standards marked below for the article  
**F** déclare la conformité suivante selon la directive CE et les normes concernant l'article  
**NL** verklaart de volgende conformiteit in overeenstemming met de EU-richtlijn en normen voor het artikel  
**E** declara la siguiente conformidad a tenor de la directiva y normas de la UE para el artículo  
**P** declara a seguinte conformidade de acordo com a directiva CE e normas para o artigo  
**S** förklarar följande överensstämmelse enl. EU-direktiv och standarder för artikeln  
**FIN** ilmoittaa seuraavaa Euroopan unionin direktiivien ja normien mukaista yhdenmukaisuutta tuotteelle  
**N** erklærer herved følgende samsvar med EU-direktiv og standarder for artikkel  
**HR** заявляє о соответствии товара следующим директивам и нормам EC  
**HR** izjavljuje sljedeću uskladenost s odredbama i normama EU za artikl.  
**RO** declară următoarea conformitate cu linia directoare CE și normele valabile pentru articolul.  
**TR** ürün ile ilgili olarak AB Yönetmelikleri ve Normları gereğince aşağıdaki uygunluk açikla masını sunar.  
**GR** δηλώνει την ακόλουθη συμφώνία σύμφωνα με την Οδηγία ΕΕ και τα πρότυπα για το προϊόν

**I** dichiara la seguente conformità secondo la direttiva UE e le norme per l'articolo  
**DK** attesterer følgende overensstemmelse i henhold til EU-direktiv og standarder for produkt  
**CZ** prohlašuje následující shodu podle směrnice EU a norem pro výrobek.  
**H** a következő konformitást jelenti ki a termékerekre vonatkozó EU-irányvonalak és normák szerint  
**SK** pojednává sledečo skladnost po smernici EU in normah za artikel.  
**PL** deklaruje zgodność wymienionego poniżej artykułu z następującymi normami na podstawie dyrektywy WE.  
**SK** vydáva nasledujúce prehlásenie o zhode podľa smernice EÚ a noriem pre výrobok.  
**BG** декларира следното съответствие съгласно директивите и нормите на ЕС за продукта.  
**UKR** заявляє про відповідність згідно з Директивою ЄС та стандартами, чинними для даного товару  
**ES** deklareerib vastavuse järgnevalele EL direktiivi dele ja normidele  
**LT** deklaruoja atitiktį pagal ES direktyvas ir normas straipsniui  
**HR** izjavljuje sledeći konformitet u skladu s odredbom EZ i normama za artikl  
**LV** Atbilstības sertifikāts apliecina zemāk minēto preču atbilstību ES direktīvām un standartiem  
**IS** Samræmisfyrirýsing staðfestir eftirfarandi samræmi samkvæmt reglum Evrópubandalagsins og stöðlum fyrir vörur

## Klima-Splitanlage Split 1200 Flat EQ C+H

- |                                                 |                                                 |
|-------------------------------------------------|-------------------------------------------------|
| <input type="checkbox"/> 98/37/EG               | <input type="checkbox"/> 87/404/EWG             |
| <input checked="" type="checkbox"/> 2006/95/EG  | <input type="checkbox"/> R&TTED 1999/5/EG       |
| <input type="checkbox"/> 97/23/EG               | <input type="checkbox"/> 2000/14/EG_2005/88/EG: |
| <input checked="" type="checkbox"/> 2004/108/EG | <input type="checkbox"/> 95/54/EG:              |
| <input type="checkbox"/> 90/396/EWG             | <input type="checkbox"/> 97/68/EG:              |
| <input type="checkbox"/> 89/686/EWG             |                                                 |

**EN 60335-1; EN 60335-2-40; EN 50366; EN 55014-1; EN 55014-2;  
EN 55022; EN 61000-3-2; EN 61000-3-3**

Landau/Isar, den 07.12.2007

  
Weichselgartner  
General-Manager

  
Wong  
Product-Management

Art.-Nr.: 23.658.21 I.-Nr.: 01017  
Subject to change without notice

Archivierung: 2365820-36-4155050-07



©  
The reprinting or reproduction by any other means, in whole or in part,  
of documentation and papers accompanying products is permitted only  
with the express consent of ISC GmbH.

© Technical changes subject to change

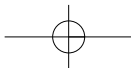

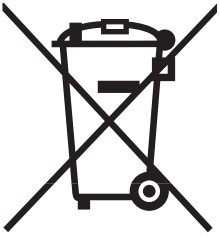

Ⓒ For EU countries only

Never place any electric tools in your household refuse.

To comply with European Directive 2002/96/EC concerning old electric and electronic equipment and its implementation in national laws, old electric tools have to be separated from other waste and disposed of in an environment-friendly fashion, e.g. by taking to a recycling depot.

Recycling alternative to the demand to return electrical devices:

As an alternative to returning the electrical device, the owner is obliged to cooperate in ensuring that the device is properly recycled if ownership is relinquished. This can also be done by handing over the used device to a returns center, which will dispose of it in accordance with national commercial and industrial waste management legislation. This does not apply to the accessories and auxiliary equipment without any electrical components which are included with the used device.

# **GUARANTEE CERTIFICATE**

**Dear Customer,**

All of our products undergo strict quality checks to ensure that they reach you in perfect condition. In the unlikely event that your device develops a fault, please contact our service department at the address shown on this guarantee card. Of course, if you would prefer to call us then we are also happy to offer our assistance under the service number printed below. Please note the following terms under which guarantee claims can be made:

1. These guarantee terms cover additional guarantee rights and do not affect your statutory warranty rights. We do not charge you for this guarantee.
2. Our guarantee only covers problems caused by material or manufacturing defects, and it is restricted to the rectification of these defects or replacement of the device. Please note that our devices have not been designed for use in commercial, trade or industrial applications. Consequently, the guarantee is invalidated if the equipment is used in commercial, trade or industrial applications or for other equivalent activities. The following are also excluded from our guarantee: compensation for transport damage, damage caused by failure to comply with the installation/assembly instructions or damage caused by unprofessional installation, failure to comply with the operating instructions (e.g. connection to the wrong mains voltage or current type), misuse or inappropriate use (such as overloading of the device or use of non-approved tools or accessories), failure to comply with the maintenance and safety regulations, ingress of foreign bodies into the device (e.g. sand, stones or dust), effects of force or external influences (e.g. damage caused by the device being dropped) and normal wear resulting from proper operation of the device.

The guarantee is rendered null and void if any attempt is made to tamper with the device.

3. The guarantee is valid for a period of 2 years starting from the purchase date of the device. Guarantee claims should be submitted before the end of the guarantee period within two weeks of the defect being noticed. No guarantee claims will be accepted after the end of the guarantee period. The original guarantee period remains applicable to the device even if repairs are carried out or parts are replaced. In such cases, the work performed or parts fitted will not result in an extension of the guarantee period, and no new guarantee will become active for the work performed or parts fitted. This also applies when an on-site service is used.
4. In order to assert your guarantee claim, please send your defective device postage-free to the address shown below. Please enclose either the original or a copy of your sales receipt or another dated proof of purchase. Please keep your sales receipt in a safe place, as it is your proof of purchase. It would help us if you could describe the nature of the problem in as much detail as possible. If the defect is covered by our guarantee then your device will either be repaired immediately and returned to you, or we will send you a new device.

Of course, we are also happy offer a chargeable repair service for any defects which are not covered by the scope of this guarantee or for units which are no longer covered. To take advantage of this service, please send the device to our service address.