

Original operating Instructions
Multiple Grinder/Sander

Einhell[®]

7

Art.-Nr.: 44.191.31

I.-Nr.: 01019

RT-XS **28**

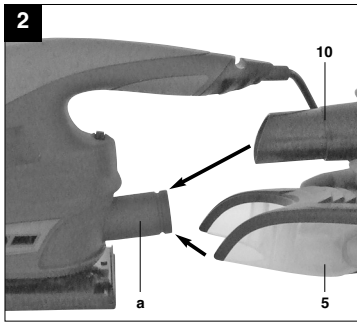
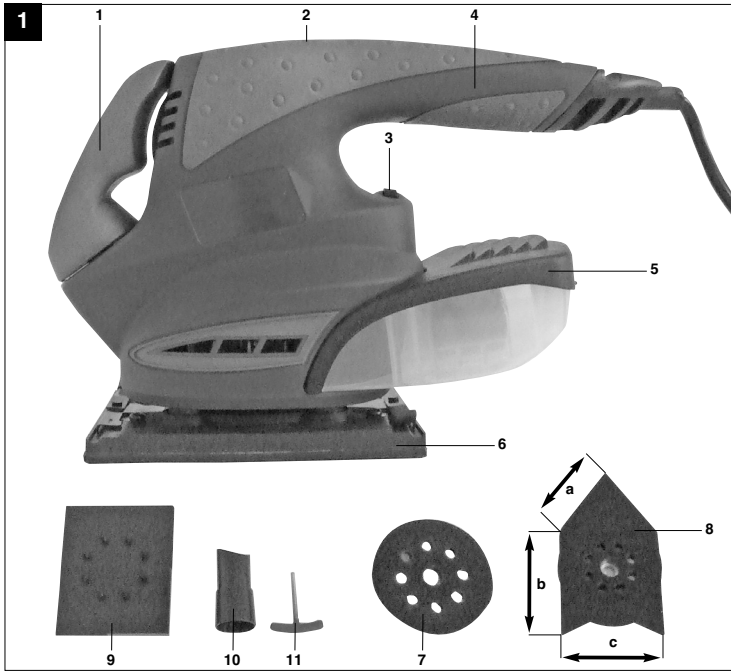

2

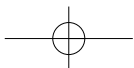
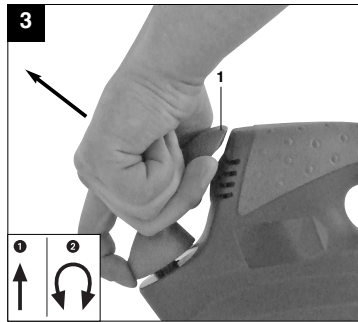

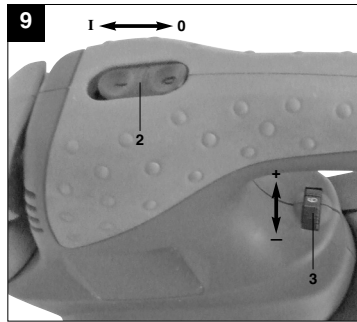
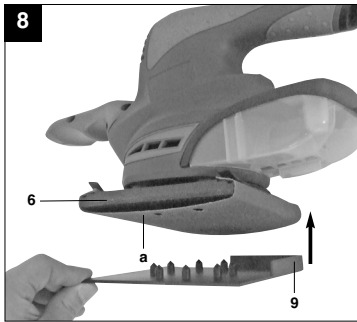
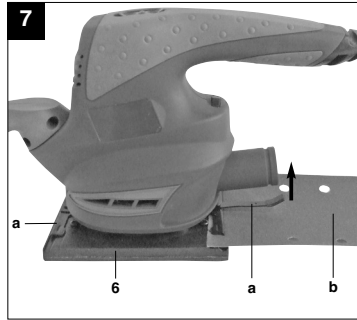
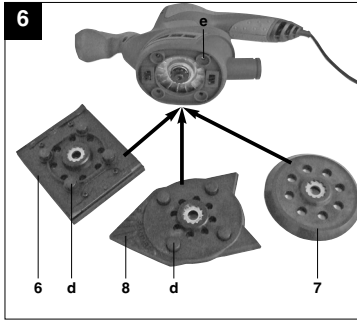
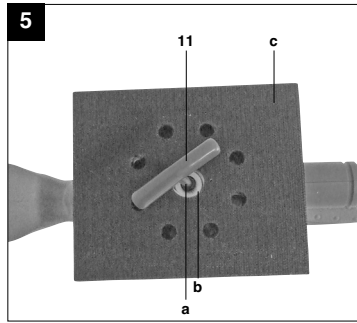
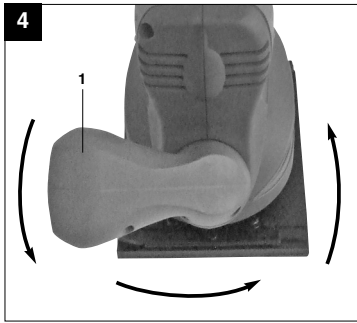

GB



"Caution - Read the operating instructions to reduce the risk of injury"



Wear ear-muffs.
The impact of noise can cause damage to hearing.



Wear a breathing mask.
Dust which is injurious to health can be generated when working on wood and other materials.
Never use the device to work on any materials containing asbestos!



Wear safety goggles.
Sparks generated during working or splinters, chips and dust emitted by the device can cause loss of sight.



⚠ Important!

When using equipment, a few safety precautions must be observed to avoid injuries and damage. Please read the complete operating manual with due care. Keep this manual in a safe place, so that the information is available at all times. If you give the equipment to any other person, give them these operating instructions as well.
We accept no liability for damage or accidents which arise due to non-observance of these instructions and the safety information.

1. Safety regulations

The corresponding safety information can be found in the enclosed booklet.

⚠ CAUTION!

Read all safety regulations and instructions.

Any errors made in following the safety regulations and instructions may result in an electric shock, fire and/or serious injury.

Keep all safety regulations and instructions in a safe place for future use.

2. Layout (Fig. 1)

1. Additional handle
2. Operating switch
3. Speed controller
4. Handle
5. Dust container
6. Rectangular sanding/grinding plate
7. Eccentric sanding/grinding plate
8. Triangular sanding/grinding plate
9. Punch for sanding/grinding paper
10. Chip extractor adapter
11. Allen key

3. Proper use

The equipment is designed for the grinding/sanding of wood, iron, plastic and similar materials using the appropriate grinding/sanding paper. The machine is not suitable for wet grinding/sanding.

The equipment is to be used only for its prescribed purpose. Any other use is deemed to be a case of misuse. The user / operator and not the manufacturer will be liable for any damage or injuries of any kind caused as a result of this.

Please note that our equipment has not been designed for use in commercial, trade or industrial applications. Our warranty will be voided if the machine is used in commercial, trade or industrial businesses or for equivalent purposes.

4. Technical data

Mains voltage:	230 V~ 50 Hz
Power input:	280 W
Orbits:	0 – 10,000 rpm
Protection class:	II /
Weight:	2.2 kg

Rectangular sanding/grinding plate:

Grinding/sanding area:	140 x 115 mm
Abrasive paper size	
(Velcro fastening system):	140 x 115 mm
Abrasive paper size	
(clamping system):	180 x 115 mm

Eccentric sanding/grinding plate:

Grinding/sanding area:	Ø 125 mm
Abrasive paper size:	Ø 125 mm

Triangular sanding/grinding plate:

Abrasive paper size:	82 x 109 x 106 mm
	(a x b x c; see Fig. 1)

Sound and vibration

Sound and vibration values were measured in accordance with EN 60745.

L_{pA} sound pressure level	80 dB(A)
K_{pA} uncertainty	3 dB
L_{WA} sound power level	91 dB(A)
K_{WA} uncertainty	3 dB

Wear ear-muffs.

The impact of noise can cause damage to hearing.

Total vibration values (vector sum of three directions) determined in accordance with EN 60745.

GB

Vibration emission value $a_{hv} = 14.495 \text{ m/s}^2$
 K uncertainty = 1.5 m/s^2

Additional information for electric power tools

Warning!

The specified vibration value was established in accordance with a standardized testing method. It may change according to how the electric equipment is used and may exceed the specified value in exceptional circumstances.

The specified vibration value can be used to compare the equipment with other electric power tools.

The specified vibration value can be used for initial assessment of a harmful effect.

Keep the noise emissions and vibrations to a minimum.

- Only use appliances which are in perfect working order.
- Service and clean the appliance regularly.
- Adapt your working style to suit the appliance.
- Do not overload the appliance.
- Have the appliance serviced whenever necessary.
- Switch the appliance off when it is not in use.
- Wear protective gloves.

Residual risks

Even if you use this electric power tool in accordance with instructions, certain residual risks cannot be ruled out. The following hazards may arise in connection with the equipment's construction and layout:

1. Lung damage if no suitable protective dust mask is used.
2. Damage to hearing if no suitable ear protection is used.
3. Health damage caused by hand-arm vibrations if the equipment is used over a prolonged period or is not properly guided and maintained.

5. Before starting the equipment

Before you connect the equipment to the mains supply make sure that the data on the rating plate are identical to the mains data.

Always pull the power plug before making adjustments to the equipment.

5.1 Installing the dust container (Figure 2/Item 5)

- Slip the dust container (5) onto the vacuum cleaner connector (a).
- The dust is extracted directly through the grinding/sanding paper and the grinding/sanding plate and into the dust container.

5.2 Installing the dust extractor adapter (Figure 2/Item 10)

Slip the dust extractor adapter (10) onto the vacuum cleaner connector (a) as shown in Figure 2. Connect the dust extractor adapter to a suitable dust extraction system.

Important.

For health safety reasons it is imperative that you use a dust container or a dust extraction system.

5.3 Adjusting the additional handle (Fig. 3/4)

- The additional handle engages in 4 positions (90° steps).
- Pull the additional handle upwards (1). (Fig. 3)
- Turn the additional handle (1) into the required working position. (Fig. 4)
- Let go of the additional handle.
- Ensure that the additional handle is securely engaged in the required position.

5.4 Fitting/removing the sanding/grinding plates (Fig. 5/6)

- Use the Allen key (11) to remove the Allen screw (a) and the washer (b) (Fig. 5).
- Then remove the sanding/grinding plate (c) (Fig. 5).
- To assemble, proceed in reverse order.
- When fitting the sanding/grinding plate (6 / 8) make sure that the 4 rubber stoppers (d) are inserted into the corresponding mounts (e). (Fig. 6)
- Check that the sanding/grinding plate is secure.

5.5 Rectangular sanding/grinding plate (Fig. 6/7/8)

Fit the rectangular sanding/grinding plate (6) to use the equipment as an orbital sander/grinder.

5.5.1 Fastening the sanding/grinding paper with a clamping system

Use of sanding/grinding paper with the corresponding dimensions and perforations (Fig. 7):

- Press the lever (a) upwards.
- Insert the sanding/grinding paper (b) into the open clamp and close the clamp.
- Lay the sanding/paper over the oscillating plate so that the paper is taut and clamp it again.
- Make sure that the perforations in the sanding/grinding paper coincide with the oscillating plate.

Use of sanding/grinding paper without the appropriate dimensions and perforations (Fig. 7/8):

- Cut the sanding/grinding paper to fit the corresponding dimensions.
- Fit the sanding/grinding paper to the sanding/grinding plate as described above.
- Place the rectangular sanding/grinding plate (6) together with the fitted sanding/grinding paper (a) onto the punch (9) for the sanding/grinding paper). (Fig. 8)
- Now punch the required holes into the sanding/grinding paper.
- Remove the punch (9) from the sanding/grinding plate (6).
- Check the correct position of the punch holes in the sanding/grinding paper.plate.

5.5.2 Fastening the sanding/grinding paper with Velcro fastening system

The Velcro fastener enables easy changing of sanding/grinding paper. Make sure that the extraction holes on the sanding/grinding paper and the sanding/grinding disk are aligned.

5.6 Triangular sanding/grinding plate (Fig. 6)

Fit the triangular sanding/grinding plate (8) to use the equipment as delta sander/grinder.

Fastening the sanding/grinding paper:

The Velcro fastener enables easy changing of sanding/grinding paper. Make sure that the vacuum extraction holes on the sanding/grinding paper and the sanding/grinding disk are aligned.

5.7 Eccentric sanding/grinding plate (Fig. 6)

Fit the eccentric sanding/grinding plate (7) to use the equipment as eccentric sander/grinder.

Fastening the sanding/grinding paper:

The Velcro fastener enables easy changing of sanding/grinding paper. Make sure that the vacuum extraction holes on the sanding/grinding paper and the sanding/grinding disk are aligned.

6. Operation

6.1 Switching the equipment ON/OFF (Fig. 9/Item 2)

To switch on: Slide the ON/OFF switch (2) forwards (position I)

To switch off: Slide the ON/OFF switch (2) backwards (position 0)

6.2 Speed control (Fig. 7/Item 3)

To pre-select the speed turn the knurled screw (3) on the switch.

Plus direction: Higher speed
Minus direction: Lower speed

6.3 Working with the equipment:

Important. Never hold the workpiece you wish to sand/grind in your hand. Secure the workpiece on a sturdy surface or with a vise.

- Place the whole surface area of the sanding disk on the material.
- Switch on the machine and move it with gentle pressure over the workpiece completely circular movements or moving it to and fro and up and down.
- Use a coarse paper for **coarse sanding** and a finer paper for **finish sanding**. You can find the best paper for the job by means of testing.

Important.

The dust generated when working with the machine may be harmful.

- Always wear goggles and a dust mask when carrying out sanding/grinding work.
- Everybody who uses the machine or enters the workplace must wear a dust mask.
- Do not eat, drink or smoke at the workplace.
- Do not use the machine on paints which contain lead.

7. Replacing the power cable

If the power cable for this equipment is damaged, it must be replaced by the manufacturer or its after-sales service or similarly trained personnel to avoid danger.



8. Cleaning, maintenance and ordering of spare parts

Always pull out the mains power plug before starting any cleaning work.

8.1 Cleaning

- Keep all safety devices, air vents and the motor housing free of dirt and dust as far as possible. Wipe the equipment with a clean cloth or blow it with compressed air at low pressure.
- We recommend that you clean the device immediately each time you have finished using it.
- Clean the equipment regularly with a moist cloth and some soft soap. Do not use cleaning agents or solvents; these could attack the plastic parts of the equipment. Ensure that no water can seep into the device.

8.2 Carbon brushes

In case of excessive sparking, have the carbon brushes checked only by a qualified electrician. Important! The carbon brushes should not be replaced by anyone but a qualified electrician.

8.3 Maintenance

There are no parts inside the equipment which require additional maintenance.

8.4 Ordering replacement parts:

Please quote the following data when ordering replacement parts:

- Type of machine
- Article number of the machine
- Identification number of the machine
- Replacement part number of the part required

For our latest prices and information please go to www.isc-gmbh.info

9. Disposal and recycling

The unit is supplied in packaging to prevent its being damaged in transit. This packaging is raw material and can therefore be reused or can be returned to the raw material system.

The unit and its accessories are made of various types of material, such as metal and plastic. Defective components must be disposed of as special waste. Ask your dealer or your local council.

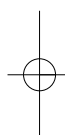
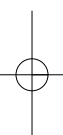

©
The reprinting or reproduction by any other means, in whole or in part,
of documentation and papers accompanying products is permitted only
with the express consent of ISC GmbH.

• Technical changes subject to change

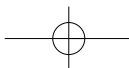

GUARANTEE CERTIFICATE

Dear Customer,

All of our products undergo strict quality checks to ensure that they reach you in perfect condition. In the unlikely event that your device develops a fault, please contact our service department at the address shown on this guarantee card. Of course, if you would prefer to call us then we are also happy to offer our assistance under the service number printed below. Please note the following terms under which guarantee claims can be made:

1. These guarantee terms cover additional guarantee rights and do not affect your statutory warranty rights. We do not charge you for this guarantee.
2. Our guarantee only covers problems caused by material or manufacturing defects, and it is restricted to the rectification of these defects or replacement of the device. Please note that our devices have not been designed for use in commercial, trade or industrial applications. Consequently, the guarantee is invalidated if the equipment is used in commercial, trade or industrial applications or for other equivalent activities. The following are also excluded from our guarantee: compensation for transport damage, damage caused by failure to comply with the installation/assembly instructions or damage caused by unprofessional installation, failure to comply with the operating instructions (e.g. connection to the wrong mains voltage or current type), misuse or inappropriate use (such as overloading of the device or use of non-approved tools or accessories), failure to comply with the maintenance and safety regulations, ingress of foreign bodies into the device (e.g. sand, stones or dust), effects of force or external influences (e.g. damage caused by the device being dropped) and normal wear resulting from proper operation of the device. This applies in particular to rechargeable batteries for which we nevertheless issue a guarantee period of 12 months.

The guarantee is rendered null and void if any attempt is made to tamper with the device.
3. The guarantee is valid for a period of 2 years starting from the purchase date of the device. Guarantee claims should be submitted before the end of the guarantee period within two weeks of the defect being noticed. No guarantee claims will be accepted after the end of the guarantee period. The original guarantee period remains applicable to the device even if repairs are carried out or parts are replaced. In such cases, the work performed or parts fitted will not result in an extension of the guarantee period, and no new guarantee will become active for the work performed or parts fitted. This also applies when an on-site service is used.
4. In order to assert your guarantee claim, please send your defective device postage-free to the address shown below. Please enclose either the original or a copy of your sales receipt or another dated proof of purchase. Please keep your sales receipt in a safe place, as it is your proof of purchase. It would help us if you could describe the nature of the problem in as much detail as possible. If the defect is covered by our guarantee then your device will either be repaired immediately and returned to you, or we will send you a new device.

Of course, we are also happy offer a chargeable repair service for any defects which are not covered by the scope of this guarantee or for units which are no longer covered. To take advantage of this service, please send the device to our service address.

Poweron Imports Limited
17 Lorien Place
East Tamaki
Manukau City 2161
Auckland
Telephone (09) 2746950